

Spectra OSW-2400 Optical SAS Switch

Transforming Data Center Tape Storage Connectivity

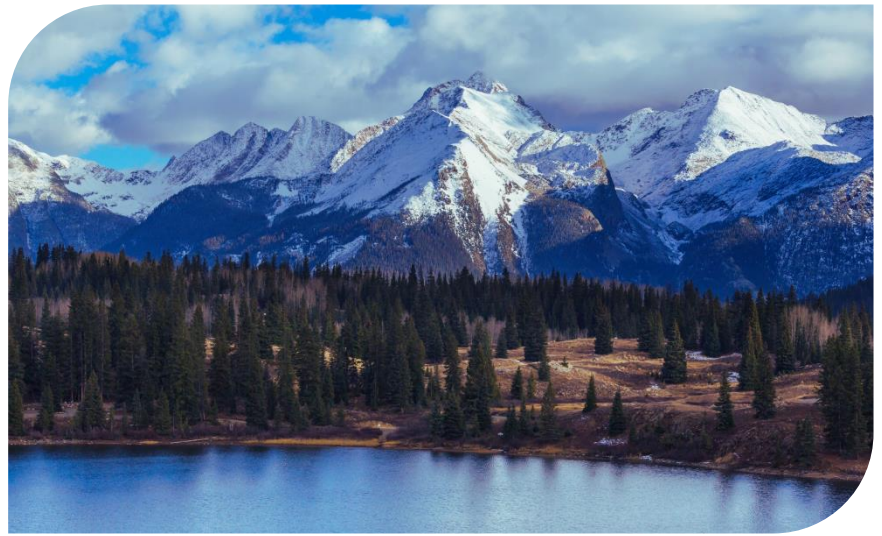

A Transformation for Tape Connectivity

Spectra® OSW-2400 Optical SAS Switch is the industry's first 24G SAS-4 switch utilizing active optical cables that extend connection distances up to 100 meters.

This innovative solution reduces or eliminates the need for Fibre Channel HBAs, switches, and cables while enabling switched topologies within data center environments—all without requiring specialized storage networking skills. The OSW-2400 switch lowers per-port costs to 1/3 of Fibre Channel while maintaining performance, scalability, and security. This allows organizations to streamline tape connectivity, enhance operational flexibility, and minimize infrastructure costs.

How it Works

The OSW-2400 switch is ideal for organizations wanting to simplify and consolidate tape connectivity, extend connectivity from rack to data center distances, or reduce reliance on Fibre Channel.

- Connects 1 to 40 SAS tape drives per switch
- Aggregates bandwidth for 108 GB/s
- Covers up to 10,000 m² data center floor space



Spectra OSW-2400 Optical SAS Switch

Spectra OSW-2400 Switch Benefits

Streamlined Standardization: Adopt SAS fabrics for simplified, more affordable infrastructure and reduce reliance on costly Fibre Channel HBAs, switches, and cables.

No Specialized Skills Needed: Optical SAS eliminates the need for advanced Fibre Channel expertise, allowing teams to manage storage environments with standard IT knowledge.

Flexible Topologies and Distance: Supports versatile configurations—one-to-many, many-to-one, or many-to-many—while extending data center connectivity for unmatched scalability.

Seamless Data Center Growth: Expand effortlessly with 48 SAS lanes and 100-meter reach, ensuring end-to-end connections for growing and dynamic data center environments.

Enhanced Data Performance: Optimize data transfers using End Device Frame Buffering (EDFB), aggregating bandwidth from diverse drive speeds for smooth, high-performance compatibility across legacy and modern devices.

Reliable Operations: Hot-swappable, dual-redundant power supplies and fans ensure uninterrupted data access and dependable performance for critical applications.

Out-of-the-box usability: Plug and Play Mode offers a seamless setup. Simply power on the OSW-2400 switch, connect your SAS cables, and the switch is operational immediately, eliminating the need for any configuration.

Advanced Security Zoning: Configurable zoning (port-to-port, port-to-lane, and lane-to-lane) protects sensitive data with compartmentalized access and ensures compliance with rigorous data protection standards.

Spectra OSW-2400 Switch Use Cases

With the Spectra OSW-2400 Optical SAS Switch, organizations can simplify tape connectivity, increase operational flexibility, and lower infrastructure costs across three use cases.

- Reduce or eliminate the use of Fibre Channel HBAs, switches and cables, and administration and maintenance costs
- Extend storage connectivity up to 100 meters or cascade switches beyond the limits of a single switch
- Enable flexible any-to-any connectivity sharing of Spectra tape libraries within data center distances

Use Case: Reduce Fibre Channel Connectivity

When upgrading or installing a new tape library, organizations transitioning from Fibre Channel can adopt SAS for new tape drives while maintaining existing Fibre Channel connections for older drives. Organizations can run Fibre Channel and SAS tape drives in parallel by adding a SAS HBA to the host and connecting new SAS drives through the OSW-2400 switch. Over time, once data is migrated or older drives are no longer needed, Fibre Channel can be phased out, leaving SAS as the primary interface. SAS infrastructure, expected to support up to LTO-13 with 12Gb speeds, ensures longevity and cost efficiency for a decade or more. This approach avoids large, upfront expenditures while enabling scalable connectivity in modern tape environments.

Use Case: Extend Storage to 100 Meters

The OSW-2400 switch enables connectivity between servers, storage, and tape libraries up to 100 meters, providing enhanced flexibility and scalability for data storage environments. By surpassing the 4-meter limitation of traditional copper SAS cables, it eliminates the need for adjacent rack space and reduces the operational burden of storage relocations, streamlining infrastructure management. Up to 10 switches may be cascaded to expand the number of fabric connections or extend connection distances beyond the limits of a single switch.

Use Case: High Availability

The Spectra OSW-2400 Optical SAS Switch can be configured for high availability by connecting dual ported tape drives to separate OSW-2400 switches for redundant paths. Dual SAS controllers on the host or single controllers on dual hosts are connected to the OSW-2400 switch, creating multiple data paths between the host and tape drives. This configuration ensures uninterrupted connectivity in the event of a path, port, or controller failure. Host-based multipath I/O software manages failover and load balancing across the redundant paths, providing continuous access to the tape drives.

Use Case: Flexible Any-to-any Connectivity

Organizations can adopt topologies like one-to-many, many-to-one, or many-to-many. A switched SAS fabric enables servers to access tape storage beyond rack-to-rack distances using optical SAS connectivity, allowing for cost-effective SAS tape drives while reducing reliance on expensive Fibre Channel infrastructure. It also offers high availability, dual-path scalability, and enhanced security via switch zoning.

Optical SAS Switch Connectivity

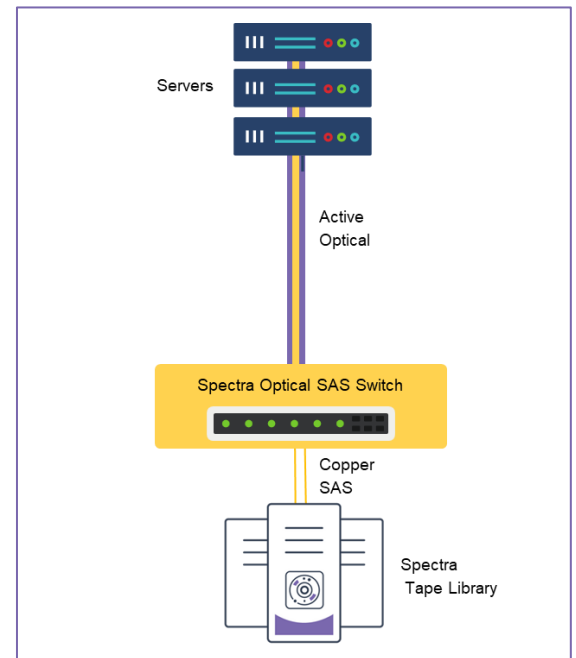

High Availability

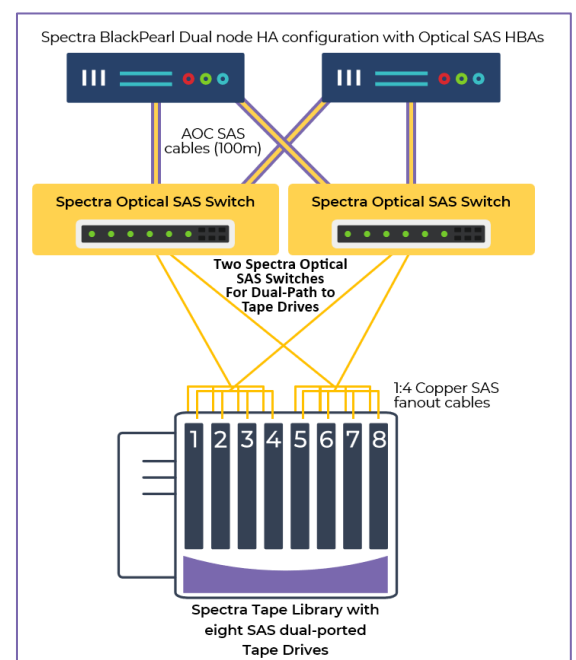

Technical Overview

Spectra OSW-2400 Optical SAS Switch

The OSW-2400 switch is a 1U/19-inch rack-mount optical SAS switch with 48 24G SAS-4 lanes configured as 12 x 4-wide ports. It can be configured for airflow from front to back or vice versa, allowing it to be mounted at the front or the back of a rack. The OSW-2400 switch extends SAS capabilities in direct-attached storage (DAS) environments by allowing multiple servers to connect to one or more independent storage systems.

Management Tools

Management can be done over Ethernet, making it straightforward to access, manage, and update it. This convenience enables efficient, remote software upgrades and configuration without downtime.

- Out-of-band management utility
- 10/100/1000 Ethernet out-of-band
- Integrated User Guide
- Customizable email notifications/alerts

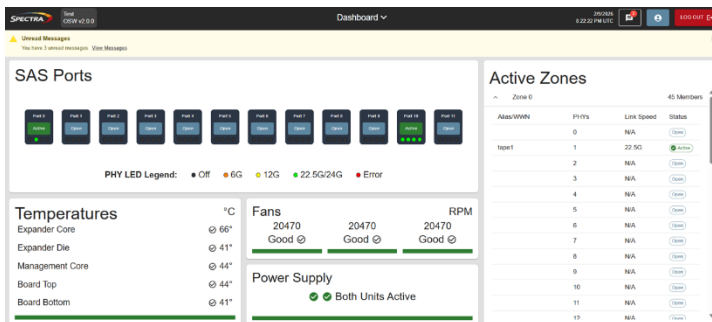

Spectra OSW-2400 Dashboard

Cable Validation

The OSW-2400 validates SFF-8644 SAS cables prior to deployment, eliminating the variable of a faulty cable. Connect both ends to any available licensed switch ports, and the switch auto-detects the test and reports pass/fail results on the GUI Tools page within seconds.

Bandwidth Aggregation

The OSW-2400 switch utilizes End Device Frame Buffering (EDFB) technology, enabling it to aggregate bandwidth from slower 400 MB/s tape drives into higher-speed 24G SAS HBAs. This means that even older or slower HBAs can still contribute to total bandwidth, maximizing overall data throughput and fully utilizing their existing storage infrastructure, without requiring costly upgrades to achieve high speeds.

Connectivity

SAS Protocols

- Serial SCSI Protocol (SSP)
- Serial ATA Tunneling Protocol (STP)
- Serial Management Protocol (SMP)

SAS Bandwidths

- Half Duplex: Wide Port (4 phys) – 90Gb/s
- Full Duplex: Wide Port (4 phys) – 180Gb/s

Cable Management

- Passive copper cables up to 4 meters
- Active optical cables up to 100 meters

SAS Compliances

- SAS-4
- SAS-3
- SAS-2

Zoning

- Port-to-port
- Port-to-lane
- Lane-to-lane

High Availability

The OSW-2400 switch provides a high-availability solution combining redundancy, security, and ease of management across storage types. It ensures reliable access to data, which is crucial for organizations that need to minimize downtime and maximize storage utilization.

Here's how it achieves this:

- 1. Redundancy and Reliability:** The OSW-2400 switch is designed with dual, hot-swappable fans and power supplies. If one fails, the other takes over without interrupting service. This hardware setup helps keep systems running even if there's a problem with one of these key components.
- 2. Dual-Path Connectivity:** Using redundant paths, you can configure two parallel switches to connect both to tape drives. If one switch goes down, the other can continue working, ensuring continuous access to the tape drive and data.
- 3. Security with Configurable Zoning:** The OSW-2400 switch supports zoning, definable to the lane, which helps compartmentalize and secure sensitive information. This zoning keeps data in separate, secure areas, adding another layer of protection and management flexibility.

Technical Specifications

Spectra OSW-2400 Optical SAS Switch	Description
Operating Systems Supported	OS independent
Optical SAS Distance	100 meters (AOC) per switch
SAS Ports	12 (Mini-SAS HD)
SAS Lanes	48 (4 lanes per port) 24Gb, 12 Gb, 6Gb
Ethernet Mgmt. Ports	1 x 1GbE
Transfer Rate per Switch	<ul style="list-style-type: none">Up to 2.25 GB/s for each SAS lane108 GB/s aggregated bandwidth
Port-to-Port Latency	<=100 ns (Passive) <=200 ns (Optical)
Devices Supported	<ul style="list-style-type: none">Supports up to 2,000 devices per switch fabricUp to 10 switches may be cascaded for greater distances and more devices
SAS Tape Drives Supported	<ul style="list-style-type: none">Up to 40 SAS tape drives per switchLTO-6, 7, 8, 9, and LTO-10IBM TS1160 and TS1170
Tape Libraries Supported	TFinity, T950, Spectra Cube, and Spectra Stack
Object Storage Supported	Spectra BlackPearl H and F-series appliances
Switch Configurations	<ul style="list-style-type: none">12, 24, 36, or 48 lanes12 lanes (3 ports) field-installed software upgrades
AC Input	100-240 VAC, 50-60 Hz
Power Supplies	Dual redundant (HA) Hot-swap 220W
Power Consumption	40 watts nominal (no active cables); 136 watts max
Airflow	<ul style="list-style-type: none">Three (HA) hot-swap fans200 Linear Feet per Minute (LFM)Air-flow configurable to either “front-to-back” or “back-to front”
Form Factor	1U rackmount
Dimensions	<ul style="list-style-type: none">Height: 4.45 centimeters (1.75 inches)Width: 43.97 centimeters (17.31 inches)Length: 30.48 centimeters (12.00 inches)
Weight	<ul style="list-style-type: none">5.9 kilograms (13.0 pounds) unboxed12.8 kilograms (28.2 pounds) boxed
Operating Environment	<ul style="list-style-type: none">Temperature: 5 to 45° C (32 to 113°F)Humidity: 5 to 90% non-condensing
Non-operating Environment	<ul style="list-style-type: none">Temperature: -10 to 85° C (14 to 185°F)Humidity: 5 to 90% non-condensing

About Spectra Logic Corporation

Spectra Logic modernizes IT infrastructures to preserve, protect and defend data, from days to decades, whether on-premises, in a single cloud, across multiple clouds or in all locations at once. Our cost-effective solutions help organizations efficiently manage, migrate and store long-term data, from terabytes to exabytes, with features that make it ransomware resilient.